

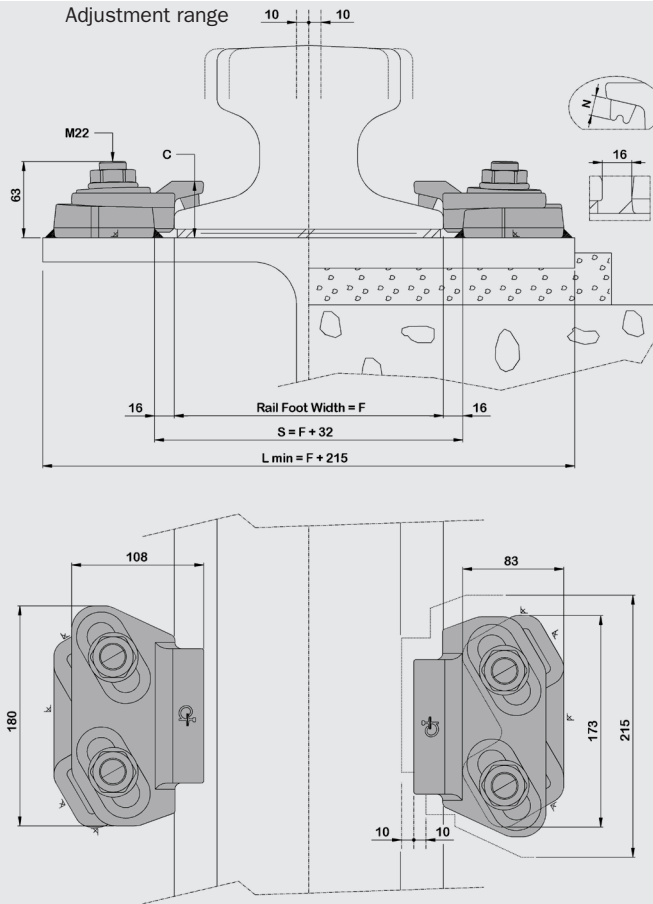

**Patented**

**New features :**

- Double wedge with patented self-contact design of inclined bolt
- Bolts incorporate a "Square Shank Base"
- Resistance to vertical forces



CLIPS	C max	Lateral adjustment	Bolt torque	Max. Resistance to lateral forces (*)	Resistance to vertical forces	Estimated weight
	mm	mm	Nm	kN	kN	kg
W30/AN	37	20	550	300	30	2.790
W30/BN	46	20	550	300	30	2.850
W30/CN	53	20	550	300	30	2.970

N: nose height, not compressed, adapted to the rail type (see table overleaf).

(\*) Higher side loads can be accepted depending on application, duty cycle and other external factors. Contact GANTREX for application conditions.

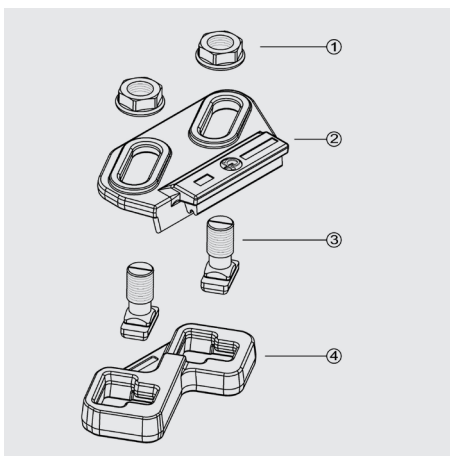

Full designation
W30/AN or W30/BN or W30/CN
Components
① 2x Sp M22 C18 GAL
② 1 x W30/32N or 1 x W30/42N or 1 x W30/49N
③ 2 x SSB M22x49 8.8 GAL
④ 1 x W30/29

**Notes overleaf**

- Clip Specification
- Clip Selection Table  
*Upper component and nose height (N) according to rail type and foot size (F).*
- Components Materials
- Installation and Welding Instructions
  - Recommended weld throat size : 6 mm; weld leg size being then 8.5 mm.
  - Any low hydrogen rod suitable for use with structural steel may be used.





### CLIP SPECIFICATION

The RailLok™ patented clips are specifically designed to facilitate correct mounting of crane rails :

- The patented design with **inclined bolt** ensures tight and full **self-contact** with the rail foot.
- Bolts with **“Square Shank Base”** allow the use of impact-wrenches.
- Easier installation because of the wider adjustment range.
- Compact design : fits narrow girders and soleplates, avoid interference with guide rollers.

Once installed, the clips are self-locking and self-tightening.

### CLIP SELECTION TABLE

	F mm	K mm	H mm	Weight kg/m	Mounting	
					with	without
					7 mm RailLok™ pad	
A120	220.0	120.0	105.0	100.00	W30/BM	W30/AJ
A150	220.0	150.0	150.0	150.30	W30/BM	W30/AJ
MRS125	180.0	120.0	180.0	125.00	W30/CM	W30/BM
MRS221	220.0	220.0	160.0	221.40	W30/BI	W30/AH
KP140	170.0	140.0	172.5	141.70	W30/CM	W30/BM

*Note : All dimensions are rounded off to serve as general guidelines only. Contact Gantrex for rail sizes not shown above and for help selecting rail pads.*

### COMPONENTS MATERIALS

The RailLok™ W30 is standard with a weldable forged steel lower component, a ductile cast iron upper component and vulcanize-bonded rubber nose. As standard, the bolts and nuts are hot dip galvanized. The upper component can also be hot dip galvanized on request.

Contact Gantrex for other options.

### INSTALLATION AND SUGGESTED WELD INSTRUCTIONS

The lower component is welded on the support parallel to the axis of the rail and the upper component is fastened to it by means of the two bolts and nuts. The recommended torque is 550 Nm. Electrical and pneumatic torque wrenches are allowed as long as the minimum torque of 450 Nm is met and the torque does not exceed 700 Nm.

It is recommended the torque is regularly controlled with a calibrated torque wrench.

For most applications, the recommended weld throat size is  $\sqrt{6}$  mm; the weld leg size is then 8.5 mm. Use any low hydrogen rod suitable for use with structural steel: ISO2560 type E 42 5 B 32 H5, E7018 or equivalent. For full instructions on weld size and electrodes, refer to the data sheet “Installation and suggested weld instructions”.

Do not apply protective coating on the contact surface between upper and lower components unless accepted by Gantrex. Do not use solvents as they may seriously damage the rubber nose.

*We reserve the right to discontinue or change specifications or design at any time without prior notice and without incurring any obligation whatsoever.*

