



GANTREX
RailLok™

www.steel.lt

RailLok™ Series

BOLTABLE grooved CLIPS - Bg15

Patent Pending

New features :

- Double wedge with patent pending self-contact design
- "Glide washer"
- "Grooved upper component"

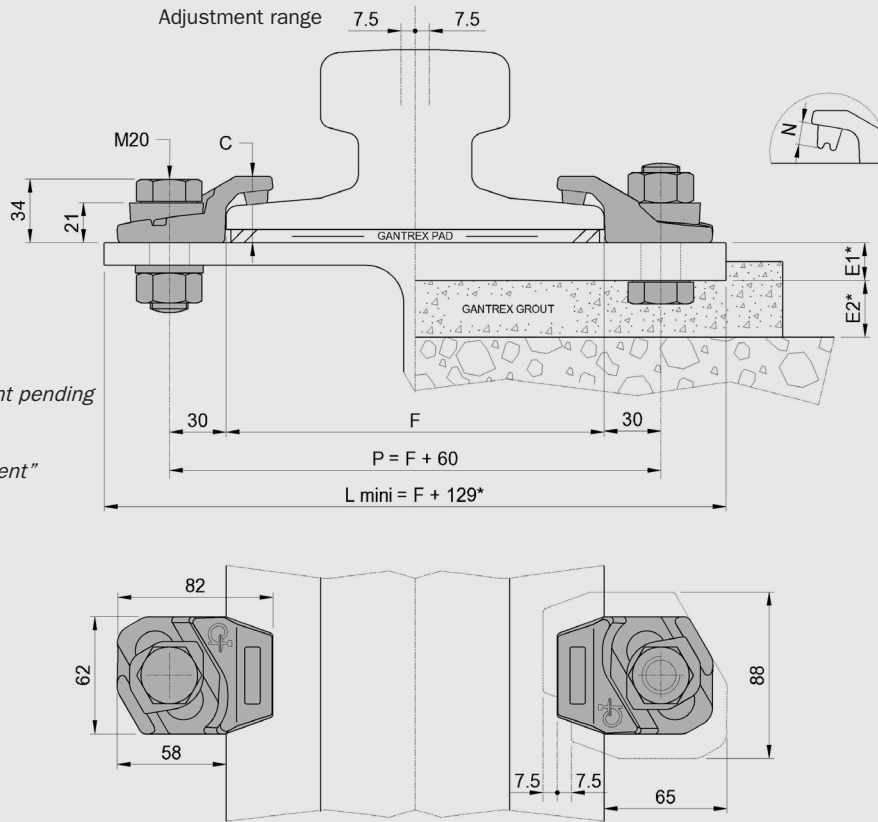

CLIPS	C max	Lateral adjustment	Bolt torque (Nm)		Estimated weight
			Bolt grade		
	mm	mm	8.8	10.9	kg
Bg15/AN	28	15	400 Nm	600 Nm	0.375
Bg15/BN	35	15			0.385
Bg15/CN	40	15			0.400
Maximum resistance to lateral forces (*)			75 kN	100 kN	

N: nose height, not compressed, adapted to the rail type (see table overleaf).

(*) Side load calculation is based on the use of 8.8 and 10.9 grade bolts, and is reduced in case of lower bolt grades.

Higher side loads can be accepted depending on application, duty cycle and other external factors.

Contact Gantrex for confirmation of side load in your application.

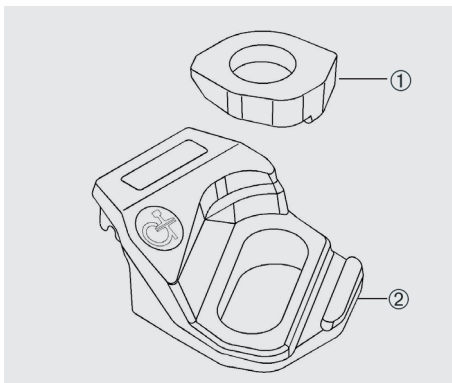

Full designation	
Bg15/AN or Bg15/BN or Bg15/CN	
Components	
① 1 x Bg15/R	WASHER
② 1 x Bg15/28N or 1 x Bg15/35N or 1 x Bg15/40N	CLIP

Notes overleaf

- Clip Specification
- Clip Selection Table
Upper component and nose height (N) according to rail type and foot size (F).
- Components Materials
- Installation Instructions

GXHQ-EN 2017-10 R3.0





CLIP SPECIFICATION

The RailLok™ clips are specifically engineered to facilitate correct mounting of crane rails:

- Patent pending design to ensure tight and full **self-contact** with the rail foot.
- Fool-proof glide washer and **grooved upper component** to make proper installation easier.
- Tightening by **impact wrench** for faster installation process.
- Lateral adjustment for better rail installation and alignment.

Once correctly installed, the clips are self-locking and self-tightening.

CLIP SELECTION FOR EACH RAIL

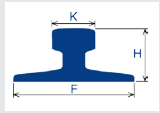
	F mm	K mm	H mm	Weight kg/m	Mounting	
					with	without
					7 mm RailLok™ pad	
A65	175.0	65.0	75.0	43.10	Bc15/BJ	Bc15/AJ
A75	200.0	75.0	85.0	56.20	Bc15/BJ	Bc15/AJ
A100	200.0	100.0	95.0	74.30	Bc15/BI	Bc15/AI
A120	220.0	120.0	105.0	100.00	Bc15/CJ	Bc15/BM
ASCE60	108.0	60.3	108.0	29.76	Bc15/BJ	Bc15/AJ
GX40 (ASCE80)	127.0	63.5	127.0	39.68	Bc15/BJ	Bc15/AJ
GX42 (ASCE85)	131.8	65.1	131.8	42.20	Bc15/BJ	Bc15/AJ
CR73	140.0	100.0	135.0	73.30	Bc15/CJ	Bc15/BM
CR100	155.0	120.0	150.0	100.20	Bc15/CH	Bc15/BI
MRS51 (104 CR)	127.0	63.5	127.0	51.59	Bc15/CJ	Bc15/BM
MRS52 (105 CR)	131.8	65.1	131.8	52.09	Bc15/BI	Bc15/AI
MRS67 (135 CR)	131.8	79.4	146.1	66.97	Bc15/CJ	Bc15/BM
MRS85 (171 CR)	152.4	101.6	152.4	84.83	Bc15/CI	Bc15/BJ
MRS87A (PRI 85R)	152.4	101.6	152.4	86.80	Bc15/CI	Bc15/BJ
MRS87B (175 CR)	152.4	102.4	152.4	86.80	Bc15/CJ	Bc15/BM
QU80	130.0	80.0	130.0	63.69	Bc15/BI	Bc15/AI
QU100	150.0	100.0	150.0	88.96	Bc15/CM	Bc15/BM
S30	108.0	60.3	108.0	30.03	Bc15/BJ	Bc15/AJ
49E1	125.0	67.0	149.0	49.39	Bc15/BJ	Bc15/AJ
S49	125.0	67.0	149.0	49.43	Bc15/BJ	Bc15/AJ
54E1 (UIC 54)	140.0	70.0	159.0	54.77	Bc15/BJ	Bc15/AJ
60E1 (UIC 60)	150.0	72.0	172.0	60.21	Bc15/BJ	Bc15/AJ

Note : All dimensions are rounded off to serve as general guidelines only. Contact Gantrex for rail sizes not shown above and for help selecting rail pads.

COMPONENTS MATERIALS

The RailLok™ Bc15 is standard with hot dip galvanized ductile cast iron components and vulcanize-bonded rubber nose.

Contact Gantrex for other options.

INSTALLATION INSTRUCTIONS

Make sure to choose the adequate bolt grade to achieve the clip side load resistance : grade 8.8 for 75 kN and 10.9 for 100 kN.

The main component is first positioned on the bolt against the rail and the special washer is then positioned on the main component with its heel into the slot of the clip. The nut is hand tightened. Once the main component is in position, use an electrical or pneumatic wrench to torque the nut.

For most applications, use bolts complying with ISO 4014 (DIN 931) or ISO 4017 (DIN 933) and the corresponding nuts and washers.

For full instructions on the use of RailLok™ boltable clips, refer to the data sheet "Installation Instructions".

Do not apply protective coating on the contact surface between components and support unless accepted by Gantrex. Do not use solvents as they may seriously damage the rubber nose.

We reserve the right to discontinue or change specifications or design at any time without prior notice and without incurring any obligation whatsoever.

